

**EDIFACT SUBSET
EDITEC
Inventory Report**



Deutscher Großhandelsverband Haustechnik e.V.



ARGE Neue Medien



**INVRPT / D.96B
Version 3.5 / November 2010**

Table of contents for the “Inventory Report” subset

1	Introduction	3
2	Explanatory notes on the Inventory Report.....	4
3	Instructions for use.....	7
4	Message structure diagram.....	8
5	History.....	9
6	Message structure of the subset.....	10
	UNA K 1 Presetting of Separators	10
	UNB M 1 Usage Data Head Segment	11
	UNH M 1 Message Head Segment.....	13
	BGM M 1 Beginning of the Message	14
	DTM M 1 Date/Time/Period Data.....	15
	RFF M 1 Reference Data	15
	NAD M 1 Name and Address.....	16
	CTA M 1 Communication partner	18
	COM K 4 Communication Link.....	18
	LIN M 1 Line Item Data	19
	PIA K 1 Additional Product Information.....	19
	DTM K 1 Date-/Time-/Period Specifications	21
	QTY M 1 Quantity	22
	INV K 1 Stock Management Data	24
	LOC M 1 Location	24
	DTM K 1 Date-/Time-/Period Specifications	24
	UNT M 1 Message End Segment	26
	UNZ M 1 Usage Data End Segment.....	26
7	Example Message	27

1 Introduction

The present EDIFACT subset regarding the message type “Inventory Report” was compiled by ITEK on behalf of Arbeitsgemeinschaft Neue Medien der deutschen Sanitärindustrie e.V. and Deutscher Großhandelsverband Haustechnik e.V.

ITEK

Technologiepark 19
33100 Paderborn

Phone no.: + 49 5251 1614 0
Fax no.: + 49 5251 1614 99
E-mail: editec@itekmbh.de

This EDIFACT subset is based on EDIFACT syntax version 3 and the following public documents:

- EDIFACT – Standardised message type “INVRPT”
- UN/EDIFACT Directory 96B, UN/ECE/TRADE/WP.4
- EDIFACT Service segments application guidelines, draft DIN 16560 part 1, February 1994
- UN/EDIFACT code list D.97A

Paderborn, November 2010

2 Explanatory notes on the Inventory Report

2.1 General notes

The Inventory Report is used to transfer inventory data from the wholesaler to the manufacturer for a range of products previously agreed upon by wholesaler and manufacturer. A prerequisite for using the Inventory report is the use of the DESADV Despatch Advice of the ORDRSP Order Response (version 3.1 or higher).

The aim is that manufacturers will carry out the stocking up on the agreed range based on the information transferred in the Inventory report message. Hence, the scheduling for this range of products will be done by the manufacturer.

This fundamental alteration to the flow of the business process will affect other messages. Orders regarding the agreed range will not be placed by the wholesaler any more, but the Despatch Advice or the Order Response will be sent by the manufacturer.

The following operational sequence applies to the process of automatic stock management by the manufacturer:

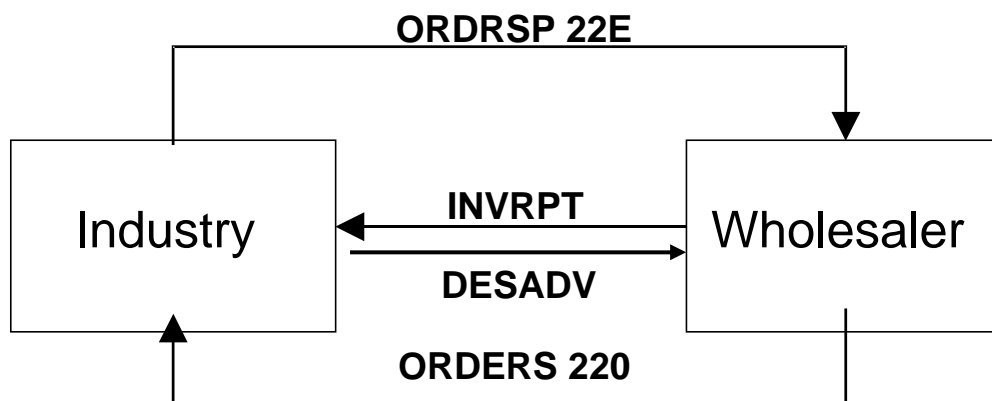

By means of the INVRPT the wholesaler can transfer an order number in the head section of the INVRPT to the manufacturer, in addition to the quantity information in the RFF segment. This order number is reserved in the wholesaler's system for an order to be generated by the manufacturer based on the values transferred in the INVRPT.

The demand identified by the manufacturer will not be shown to the wholesaler by a separate ORDERS message, but by DESADV or by an Order Response with code 22E in the BGM segment. The order number in the ORDRSP message will be the same as the one transferred by the wholesaler in the INVRPT. If the wholesaler fails to transfer an order number in the INVRPT, an order number will be generated at the manufacturer's.

The original EDITEC-ORDRSP 3.0 message has been supplemented by the Qualifier 22E in the BGM segment.

The INVRPT does not provide any information on time requirements on the wholesaler's part. The wholesaler can now transfer his open customer orders (e.g. orders placed with the wholesaler by the trade) to the manufacturer. For this, code 220 has been included in the BGM in the ORDERS message. This code indicates that the ORDERS constitutes a customer order placed with the wholesaler. An ORDERS with code 220 in the BGM segment will therefore not generate any immediate movement of goods but serves information purposes only.

If the INVRPT is used to transfer the "open orders (stock orders) (code 73)" instead of the "quantity of goods received (Code 48)", the status of open orders placed with the industry by the wholesaler can be transferred additionally as ORDERS with code "248". Based on this information the industry will be able to determine the open rollstock.

2.2 References in the messages

INVRPT example message:

UNA:+.? '
UNB+UNOC:3+X:52+Y:65+010308:1107+123+X'
UNH+111111111+INVRPT:D:96B:UN'
BGM+35+0815'
DTM+137:20001222:102'
RFF+ACE: 01321864864 '
NAD+SU+4300001000009::9++Institut für Technologietransfer:in der elektronischen Kommunikation+Technologiepark 19+Paderborn++33100+DE'
CTA++:HerrMüller'
LIN+1++4312345123459:EN'
PIA+1+123456:MF'
QTY+145:9:PCE'
DTM+50:20011222:102'
QTY+48:3:PCE'
QTY+216:25:PCE'
UNT+13+111111111'
UNZ+1+123'

ORDRSP example message sent to the wholesaler by the manufacturer based on the Inventory Reports:

UNA:+.? '
UNB+UNOC:3+Y:65+X:52+010308:1107+123'
UNH+1+ORDRSP:D:96B:UN:DESN11'
BGM+22E+123456'
DTM+4:20010308:102'
DTM+2:20010311:102'
RFF+VN: 01321864864 '
NAD+SU+4300001000009::9++Institut für Technologietransfer:in der elektronischen Kommunikation+Technologiepark 19+Paderborn++33100+DE'
LIN+1++4312345123459:EN'
QTY+12:10:PCE'
UNT+12+1'
UNZ+1+123'

3 Instructions for use

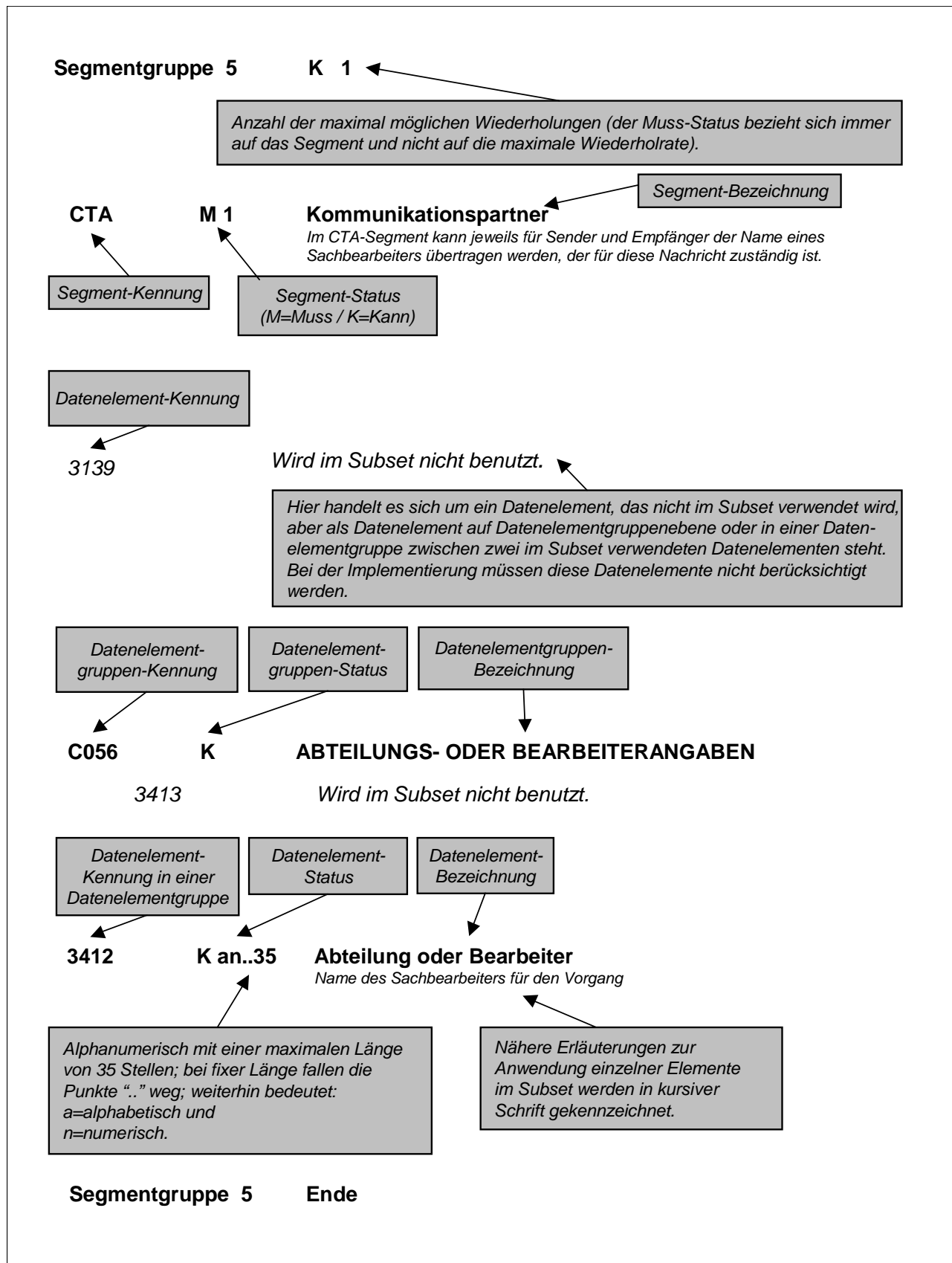

4 Message structure diagram

The following illustration shows the message structure of the “Inventory Report” subset complete with segment status and maximum repetition frequency.

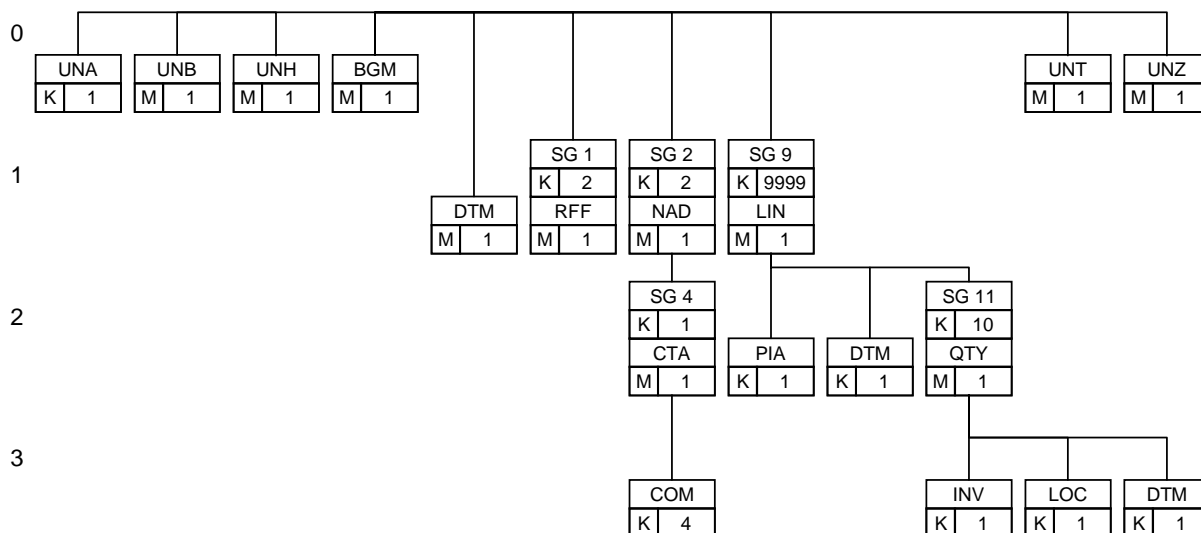

5 History

Alteration date	Segment	Alteration
29/09/2008	UNB/S002/0007	Inclusion of qualifier "14" Sender ILN
29/09/2008	UNB/S003/0007	Inclusion of qualifier "14" Recipient ILN
02/10/2008	PIA/C212/7143	Additional qualifier "XLK" Destination warehouse of the stock transfer
02/10/2008	SG11/QTY/6063	Additional qualifier "48A" Transfer quantity outgoing "48Z" Transfer quantity incoming
02/10/2008	SG11	Repetition frequency increased to 10
16/03/2009	SG4	Inclusion of the communication addresses segment
18/05/2009	SG11	Inclusion of the new INV and LOC segments
18/05/2009	PIA/C212/7143	Deletion of the additional qualifier "XLK" Destination warehouse of the stock transfer

6 Message structure of the subset

UNA K 1 Presetting of Separators

In the UNA segment, separators, decimal marks and release indicators are predefined. It is defined only once and applies to the following messages until it is revoked. Consequently, it won't be transferred furthermore.

If needed, value :+,? '

: separates data elements in a data element group

+ separates segment designations, data element groups and data elements

, Decimal marker (comma)

? Release indicator, restores the original meaning of the mark that follows the release indicator.

Blank space, reserved for later applications

' Segment terminator

UNB M 1 Usage Data Head Segment

The UNB segment transfers data concerning syntax, sender/recipient of the interchange file, date and time of its creation, and a data exchange reference. Optionally, a password for the recipient may be included in the transfer as well.

S001 M SYNTAX DESIGNATOR**0001** M a4 Syntax Identifier*Constant Value:*

<i>"UNOC"</i>	<i>EDIFACT syntax version C</i>
---------------	---------------------------------

0002 M n1 Syntax Version Number*Constant Value:*

<i>"3"</i>	<i>EDIFACT syntax version 3</i>
------------	---------------------------------

S002 M SENDER OF THE INTERCHANGE FILE**0004** M an..35 Sender Designation*Sender Identifier (e. g. identification number in Telebox400)***0007** K an..4 Participant Designation, Qualifier

This data element serves the definite specification of the participants. The following codes are available:

<i>"52"</i>	<i>INS (IBM Network Services)</i>
<i>"65"</i>	<i>Telebox400 (Deutsche Telekom)</i>
<i>"ZZZ"</i>	<i>Other network operators</i>
<i>"14"</i>	<i>Sender ILN</i>

S003 M RECIPIENT OF THE INTERCHANGE FILE**0010** M an..35 Recipient Designation*Recipient Identifier (e. g. identification number in Telebox400)***0007** K an..4 Participant Designation, Qualifier

This data element serves the definite specification of the participants. The following codes are available:

<i>"52"</i>	<i>INS (IBM Network Services)</i>
<i>"65"</i>	<i>Telebox400 (Deutsche Telekom)</i>
<i>"ZZZ"</i>	<i>Other network operators</i>
<i>"14"</i>	<i>Recipient ILN</i>

S004	M		DATE/TIME OF CREATION
0017	M	n6	Date of Creation <i>Date of creation of the message by the sender in the format "YYMMDD". (This format is prescribed according to the EDIFACT implementation guidelines for service segments).</i>
0019	M	n4	Time of Creation <i>Format: HHMM</i>
0020	M	an..14	DATA EXCHANGE REFERENCE <i>Number for each communication address (X.400, provider, ...) and mes- sage/data type, consistently rising in ascending order. The data ex- change reference number serves as a plausibility test for the identifica- tion of double transmissions and failed transmissions. This task is ful- filled by the converter.</i>
S005	K		REFERENCE/PASSWORD OF THE RECIPIENT
0022	M	an..14	Reference or password of the recipient <i>A password grants access to the recipient's network or user system. The sender and recipient may agree upon a password bilaterally.</i>

UNH M 1 Message Head Segment

In the UNH segment, a message is identified unambiguously. The ED-ITEC subset "Inventory Report" is based on the message type "INVRPT".

0062 M an..14 MESSAGE REFERENCE NUMBER

In each transfer file, every message is consistently numbered in ascending order, beginning with "1". This task is fulfilled by the converter.

S009 M MESSAGE IDENTIFIER**0065** M an..6 Message Type Identifier

Constant Value:

"INVRPT"	<i>Inventory Report</i>
----------	-------------------------

0052 M an..3 Version Number of the Message Type

Constant Value:

"D"	<i>Draft version/UN/EDIFACT Directory</i>
-----	---

0054 M an..3 Release Number of the Message Type

Constant Value

"96B"	<i>Release 1996 - B</i>
-------	-------------------------

0051 M an..2 Administrative Organisation, encoded

Constant Value:

"UN"	<i>UN/ECE/TRADE/WP.4</i>
------	--------------------------

0057 K an..6 Operational Code of the Organisation in Charge

Constant Value:

"ITEK35"

BGM M 1 Beginning of the Message

In the BGM segment the purpose and name of the message are defined.

C002 K DOCUMENT/MESSAGE NAME

1001 K an. 3 Document/Message Name, encoded

The following codes are available:

“33E”	<i>Inventory situation report (NO replenishment delivery)</i>
“35”	<i>Inventory report</i>
“35E”	<i>Inventory report from industry to commerce (separate code)</i>

By means of the code “33E” the wholesaler can additionally transfer inventory data regarding articles that are not participating in the Lo-GH-In procedure (automatic scheduling between wholesaler and industry). In this way storage transparency can also be generated for these articles.

Alternatively, all articles participating in the Lo-GH-In procedure as well as those not participating in the Lo-GH-In procedure can be transferred in a transfer file with the code “35”.

C106 K DOCUMENT/MESSAGE IDENTIFICATION

1004 K an..35 Document/message number

Number of the Inventory Report

DTM M 1 Date/Time/Period Data

C507 M DATE/TIME/PERIOD DATA

2005 M an..3 Date/Time/Period Data, Qualifier

The following codes are available:

"137" <i>Date of the Inventory Report</i>

2380 K an..35 Date/Time/Period Data

Date, formatted as indicated in data element 2379.

2379 K an..3 Date/Time/Period Data, Format, Qualifier

The following codes are available:

"102" <i>Format: YYYYMMDD</i>

Segment group 1 **K 2**

RFF M 1 Reference Data

C506 M REFERENCE DATA

1153 M an..3 Reference, Qualifier

The following codes are available:

"ACE" <i>Wholesaler's transaction number</i>
"AAS" <i>Store number</i>

1154 K an..35 Reference Number

Number or reference in relation to the qualifier chosen in data element 1153.

Segment group 1 **End**

Please note:

The wholesaler's transaction number is an order number generated by the manufacturer reserved for orders that the wholesaler is supposed to transfer with this message. If a reserved order number is transferred here, the manufacturer will have to send it back with the next Order Response. If no order number is transferred by the wholesaler, the manufacturer will have to generate an order number. No order number is required though for the transfer of the DESADV.

Segment group 2 K 2

This segment group contains the NAD segment and segment group 5 and serves the indication of the partners and locations involved in the message.

NAD M 1 Name and Address

In the NAD segment data concerning the identification of the partners involved as well as important address data are transferred.

3035 M an..3 PARTNER, QUALIFIER

The following codes are available:

"SU"	Supplier (Manufacturer)
"WS"	Wholesaler

C082 K IDENTIFICATION OF THE PARTNER**3039 M an..35 Partner Identification Number, encoded**

In dependence of the qualifier stated above, the identification number of the partner is stated here.

1131 *Is not used in the subset.*

3055 K an..3 Administrative Organisation, encoded

The following codes are available:

"9"	EAN (CCG as the German issuer of the ILN numbers)
"ZZZ"	bilaterally agreed upon (customer- and supplier numbers)

C058 IS NOT USED IN THE SUBSET.

C080 K NAME OF THE PARTNER**3036 M an..35 Name of the partner**
*Name 1 of the partner.***3036 K an..35 Name of the partner**
*Name 2 of the partner.***C059 K STREET****3042 M an..35 Street and house number****3164 K an..35 LOCATION**

3229 *IS NOT USED IN THE SUBSET.*

3251 K an..9 POSTAL CODE

3207 K an..3 COUNTRY, ENCODED

The most important country codes according to ISO 3166:

DE = GERMANY

FR = FRANCE

GB = UNITED KINGDOM

US = UNITED STATES

... See Appendix for further codes

Segment group 4 K 1

This segment group contains the CTA segment for the indication of a contact person.

CTA M 1 Communication partner

The CTA segment is used to transfer the name of the contact person/official in charge of the partner concerned.

3139 *IS NOT USED IN THE SUBSET*

C056 K DATA ON THE DEPARTMENT OR THE OFFICIAL IN CHARGE

3413 *Is not used in the subset.*

3412 K an..35 Department or Official in Charge
Name of the department or the official in charge.

COM K 4 Communication Link

A segment for the indication of the communication number and type of the official in charge or the department referred to in the CTA segment.

C076 M COMMUNICATION LINK

3148 M an..512 Communication Number

3155 M an..3 Communication Channel/Service, Qualifier
The following codes are available:

<i>"AH"</i>	<i>Internet Address (World Wide Web)</i>
<i>"EM"</i>	<i>E-Mail</i>
<i>"FX"</i>	<i>Facsimile</i>
<i>"TE"</i>	<i>Telephone</i>

Segment group 4 End
Segment group 2 End

Segment group 9 **K** **9999**

LIN **M** **1** **Line Item Data**

In the LIN segment line items are transferred following a current serial number (line item number).

1082 **K** **n..6** **LINE ITEM NUMBER**
Current serial line item number.

1229 *IS NOT USED IN THE SUBSET.*

C212 **K** **GOODS-/SERVICE IDENTIFICATION**

7140 **K** **an..35** **Goods-/Service Number**
Article number

7143 **K** **an..3** **Goods-/Service Number, encoded**
The following codes are available:

<i>"EN"</i>	<i>EAN (European Article Number)</i>
<i>"MF"</i>	<i>Manufacturer's article number</i>

PIA **K** **1** **Additional Product Information**

4347 **M** **an..3** **PRODUCT IDENTIFICATION FUNCTION**
Constant Value:

<i>"1"</i>	<i>Additional Product Information</i>
------------	---------------------------------------

C212 **M** **GOODS-/SERVICE IDENTIFICATION**

7140 **K** **an..35** **Goods-/Service Number**
Article number

7143 **K** **an..3** **Goods-/Service Number, encoded**
The following codes are available:

<i>"MF"</i>	<i>Manufacturer's article number</i>
-------------	--------------------------------------

C212 K GOODS-/SERVICE IDENTIFICATION**7140** K an..35 Goods-/Service Number
*Wholesaler's article number***7143** K an..3 Goods-/Service Number, encoded
The following codes are available:

<i>"VN" Wholesaler's article number</i>

C212 K GOODS-/SERVICE IDENTIFICATION**7140** K an..35 Goods-/Service Number
*Wholesaler's storage location; its usage has to be agreed upon bilaterally.***7143** K an..3 Goods-/Service Number, encoded
The following codes are available:

<i>"XLO" Bilaterally agreed, here: wholesaler's storage location (separate code)</i>
--

C212 K GOODS-/SERVICE IDENTIFICATION**7140** K an..35 Goods-/Service Number
*Wholesaler's storage location; its usage has to be agreed upon bilaterally.***7143** K an..3 Goods-/Service Number, encoded
The following codes are available:

<i>"XLP" Bilaterally agreed, here: wholesaler's storage location (separate code)</i>
--

DTM **K 1** **Date-/Time-/Period Specifications**

This DTM segment is used to indicate the number of days until the next replenishment provided by the supplier.

C507 **M** **DATE-/TIME-/PERIOD SPECIFICATIONS****2005** **M an..3** **Date-/Time-/Period Specifications, Qualifier**

The following codes are available:

<i>"169"</i>	<i>Replenishment respond time</i>
--------------	-----------------------------------

2380 **M an..35** **Date-/Time-/Period Specifications**

Number of days required for replenishment

0 = Availably immediately

1-998 = Number of days required for replenishment

999 = Upon request

2379 **M an..3** **Date-/Time-/Period Specifications, Format, Qualifier**

Constant Value:

<i>"804"</i>	<i>Days</i>
--------------	-------------

Segment group 11 **K** **999**

QTY M 1 Quantity

The QTY segment is used to transfer stock quantities.

C186 M QUANTITY DATA

6063 M an..3 Quantity, Qualifier

The following codes are available:

"48"	Quantity of goods received
"73"	Open orders (stock orders)
"98"	Maximum inventory
"97"	Minimum inventory
"143"	Backlog (immediate delivery required)
"145"	Inventory (physical stock)
"216"	Quantity reserved
"230"	Monthly requirements (separate code)
"48Z"	Transfer quantity incoming
"48A"	Transfer quantity outgoing

6060 M n..15 Quantity

Quantity with a maximum of three decimal fractions.

6411 K an..3 Unit of measurement, Qualifier

The following codes are available:

"CMK"	Square centimetre
"CMQ"	Cubic centimetre
"CMT"	Centimetre
"DZN"	Dozen
"GRM"	Gramme
"HLT"	Hectolitre
"KGM"	Kilogramme
"KTM"	Kilometre
"LTR"	Litre
"MMT"	Millimetre
"MTK"	Square metre
"MTQ"	Cubic metre
"MTR"	Metre
"NRL"	Number of rolls
"PCE"	Piece
"PR"	Pair
"SET"	Set
"TNE"	Tonne

Explanatory notes on the quantities in the QTY segment:

Code value	Denomination	Definition	Status
"48"	Quantity of goods received	Quantity alteration to the active inventory. All goods receipts per item executed on one day are summarized under this point. The latest goods receipt may be transferred. In addition the date of goods receipt may be transferred.	M* ¹
"73"	Open orders (open order status)	All stock orders of the storage to be scheduled are transferred summarized under open orders. The origin of the order is not taken into consideration, i.e. also orders placed via telephone or fax have to be transferred.	M*
"97"	Minimum inventory	The minimum inventory is agreed upon bilaterally between wholesaler and industry. ²	K
"98"	Maximum inventory	The maximum inventory is agreed upon bilaterally between wholesaler and industry. ³	K
"143"	Backlog (immediate delivery required)	The backlog is included in the quantity reserved. By delivering the backlog, the entire demand ⁴ determined by the supplier should be delivered as a rush order. The backlog transferred is always a positive value. (Negative values are not transferred.)	K
"145"	Inventory (physical stock)	The physical stock to be found in the warehouse (inventory)	M
"216"	Quantity reserved	The quantity reserved comprises the customers' orders with the wholesaler for n weeks. The number of weeks is determined by the wholesaler.	M
"230"	Monthly requirements (separate code)	The monthly requirement is the demand forecast by the wholesaler for the next 4 weeks. This code is transferred for information purposes only.	K

The M = Must status indicates whether the information have to be transferred with the INVRPT. Values with K = Can status can be transferred. For M* see footnote 1 (cf. p. 23).

¹ Either the quantity of goods received or the number of open orders has to be transferred. It is also possible to transfer both values. If both values are transferred, the quantity of goods received may not be deducted from the open orders any more.

² It is recommended not to transfer the minimum inventory more often than once a month.

³ It is recommended not to transfer the maximum inventory more often than once a month.

⁴ The requirements identified are the demand calculated by the industry for the wholesaler based on the bilaterally agreed quantities.

INV **K 1** **Stock Management Data****4501** **M AN..1** **DIRECTION OF THE STOCK MOVEMENT, ENCODED***The following codes are available:*

"1"	Outward stock movement
"2"	Inward stock movement

LOC **M 1** **Location***In the LOC segment the point of sale has to be transferred.***3227** **M an..3** **LOCATION, QUALIFIER***Constant Value:*

"249"	Inventory location
-------	--------------------

C517 **M** **LOCATION****3225** **M an..25** **Location***Identification of the location*

1131

*Is not used in the subset.***3055** **M an..3** **Administrative Organisation, encoded***The following codes are available:*

"ZZZ"	bilaterally agreed
-------	--------------------

3224 **K an..70** **Location***Textual indication of the location***DTM** **K 1** **Date-/Time-/Period Specifications****C507** **M** **DATE-/TIME-/PERIOD SPECIFICATIONS****2005** **M an..3** **Date-/Time-/Period Specifications, Qualifier***The following codes are available:*

"50"	Date of receipt of goods
------	--------------------------

2380 K an..35 Date-/Time-/Period Specifications
Date, formatted as indicated in data element 2379.

2379 K an..3 Date-/Time-/Period Specifications, Format, Qualifier
Constant Value:

<i>"102" Format: YYYYMMDD</i>

Segment group 11
Segment group 9

End
End

UNT M 1 Message End Segment

In the UNT segment the number of segments and a message reference number are transferred for the purpose of a plausibility verification.

0074 M n..6 NUMBER OF SEGMENTS IN A MESSAGE

Number of segments transferred with this message, including the UNH and UNT segments.

0062 M an..14 MESSAGE REFERENCE NUMBER

Here, the same reference number as in UNH / 0062 has to be entered. Upon receipt of message, this number is compared to the entry in the UNH segment.

UNZ M 1 Usage Data End Segment

In the UNZ segment a data exchange counter and a data exchange reference may be transferred.

0036 M n..6 DATA EXCHANGE COUNTER

Here, the number of messages is entered in the usage data frame UNB...UNZ.

0020 M an..14 DATA EXCHANGE REFERENCE

The same reference number as in UNB / 0020 has to be entered here. Upon receipt of message, this number is compared to the entry in the UNB segment.

7 Example Message

UNA:+.? '
UNB+UNOC:3+4399901598867:52+Supplier-DE:52+050401:1359+1+PSWD'
UNH+1+INVRPT:D:96B:UN:ITEK33'
BGM+35+47110192'
DTM+137:20050330:102'
RFF+ACE:456123'
NAD+SU+4300001000009::9++Example Company:GmbH&Co.KG+Example Street
1+Example City++59959+DE'
CTA++:Ms Example'
LIN+1++4312345123459:MF'
PIA+1+123456:MF+123456:VN+654321:XLO+321654:XLP'
DTM+169:20:804'
QTY+48:9:PCE'
DTM+50:20050401:102'
QTY+48:9:PCE'
DTM+50:20050415:102'
QTY+48:32:PCE'
DTM+50:20050430:102'
LIN+2++3123454123459:MF'
...'
UNT+26+1'
UNZ+1+1'